

DEFINING RUGGED

EXCEPTIONAL ENGINEERING | ROCK SOLID | EXTENSIVE TESTING



FORKLIFT MOUNT: DUAL CLAM SHELL WITH 3" ARM AND SMALL PLATE

Placement	Tilt	Swivel	Weight	Height	Width	Depth
Attaches to rectangular forklift support braces guard leg 1.5" to 2.5" wide	Yes - Clevis up to 90° fore Yes - Clam Shell up to 160°	Motion Attachment - 360° Entire arm - 360°	7.95 lbs.	10.08"	7.43"	9.96"

Clam Shell Features:

- Heavy gauge steel construction for long-term durability in a rugged environment
- Black powdercoat finish for maximum corrosion resistance
- *Clam Shell* features the following hole patterns: AMPS, NEC, 75mm VESA, Gamber-Johnson 2"x 4.09"
- The entire arm can rotate around 360° and the Motion Attachment can also rotate 360°
- Arm extends 3" bringing equipment closer to the user
- Arm can be tighten down to be locked into a permanent position
- Tilt capabilities:
 - 90° forward allows for tablets to be easily mounted
 - 26° aft movement with a positive stop at 26°
 - Riveted design allows for smoother tilt movement
- To tilt the *Clam Shell* simply loosen the adjustable lever, tilt to desired position and then re-tighten the lever
- A secondary bolt is included to lock the clevis into a permanent position
- Limited Lifetime Warranty

Small Plate Features

- Heavy gauge steel construction for long-term durability in a rugged environment
- Black powdercoat finish for maximum corrosion resistance
- *Clam Shell* features the following hole patterns: AMPS, NEC and 75mm VESA
- The *Clam Shell* can be tilted up or down for a total of 160°
- To tilt the *Clam Shell* simply loosen the adjustable lever, tilt to desired position and then re-tighten the lever
- A secondary bolt is included to lock the clam shell into a permanent position
- Plate sandwiches the overhead guard leg and allows user to position the device at the desired height position
- Limited Lifetime Warranty

Item No. **7160-0420**

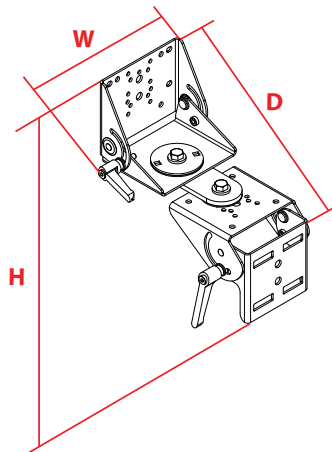

Very Well Connected™

3001 Borham Ave. | Stevens Point, WI 54481, USA
 Phone: 715.344.3482 | Toll-free: 800.487.9220 | Fax: 715.344.5209
 Email: gamberj@gamberjohnson.com | Website: www.gamberjohnson.com

Follow us on:



This document, including images, may not be reproduced partly or fully without the expressed written consent of Gamber-Johnson's Marketing Department.
 © Copyright 2016 Gamber-Johnson LLC