

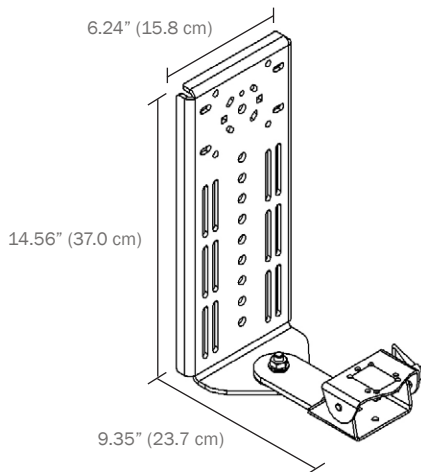

# Forklift Low Profile Tablet Keyboard Bracket

Engineered for the demanding work environment in material handling

This keyboard bracket features a 3" arm and mini clevis to give you the flexibility to rotate and tilt your keyboard to any desired position. You can also mount a tablet docking station or cradle using the following hole patterns: AMPS, NEC, 75mm VESA, and Gamber 2x4. Its low profile design means you can save more space and maximize your mobile workplace.



Dimensions: 14.56" (37.0 cm) H x 6.24" (15.8 cm) W x 9.35" (23.7 cm) D  
Weight: 6.8 lbs. (3.08 kg)



## Features

- Black powdercoat finish for maximum corrosion resistance.
- Heavy gauge steel construction for long-term durability in a rugged environment.
- Rotating 3" arm and Mini Clevis provides independent keyboard adjustability.
- Designed to be used with any keyboard using the AMPS and NEC hole pattern.
- Bracket features the following hole patterns for dock/cradle mounting: AMPS, NEC, 75mm VESA, Gamber-Johnson 2" x 4.09".
- Bracket is compatible with any Gamber-Johnson clam shell or clevis.
- Provides smaller overall profile compared to other keyboard mounting products.
- Limited lifetime warranty.

## Product number

7160-0984